

ZENNAROTRAFO

energy passes through us.

...since 1946.

Introduction

ZENNARO® has developed its own structure becoming a leader in manufacturing transformers of the following type:

- Oil-filled distribution and power transformers from 25 KVA to 20000 KVA / 36 KV
- Dry type transformers
- Cast resin transformers up to 5000 KVA / 36KV
- Earthing auxiliary transformers
- Reactors

Two manufacturing plants in Marghera (Venice) and a relevant export share are a guarantee of continuity and development.

Quality and Standards

Since the beginning, ZENNARO® has always focused on constant quality upgrading in all sectors: *planning, production, technology and organization.*

ZENNARO® transformers are designed to meet all the most recent national and international standards such as IEC, ANSI/IEEE, CEN/ CENELEC, BS, DIN/VDE.

Since 1997 ZENNARO® has been a certified company according to ***UNI EN ISO 9001*** standards able to supply a wide of range of highly reliable products and a high quality service.

Since 1999 ZENNARO® is a qualified supplier for the Italian Electricity Company (ENEL) with HV/LV distribution transformers, transformers forming neutral (TFN), earthing transformers and reactors.

Oil-Filled Transformer

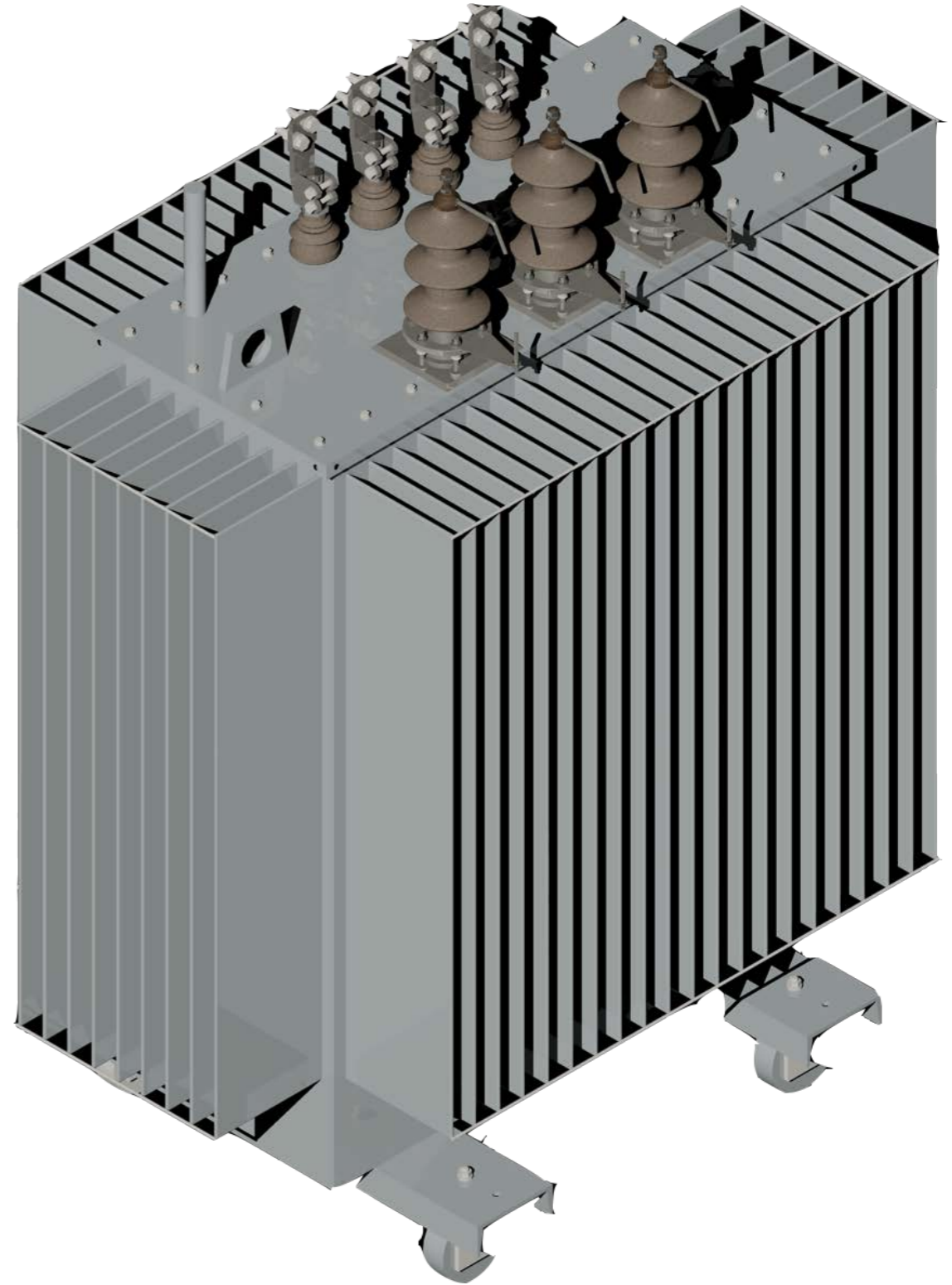

The Core

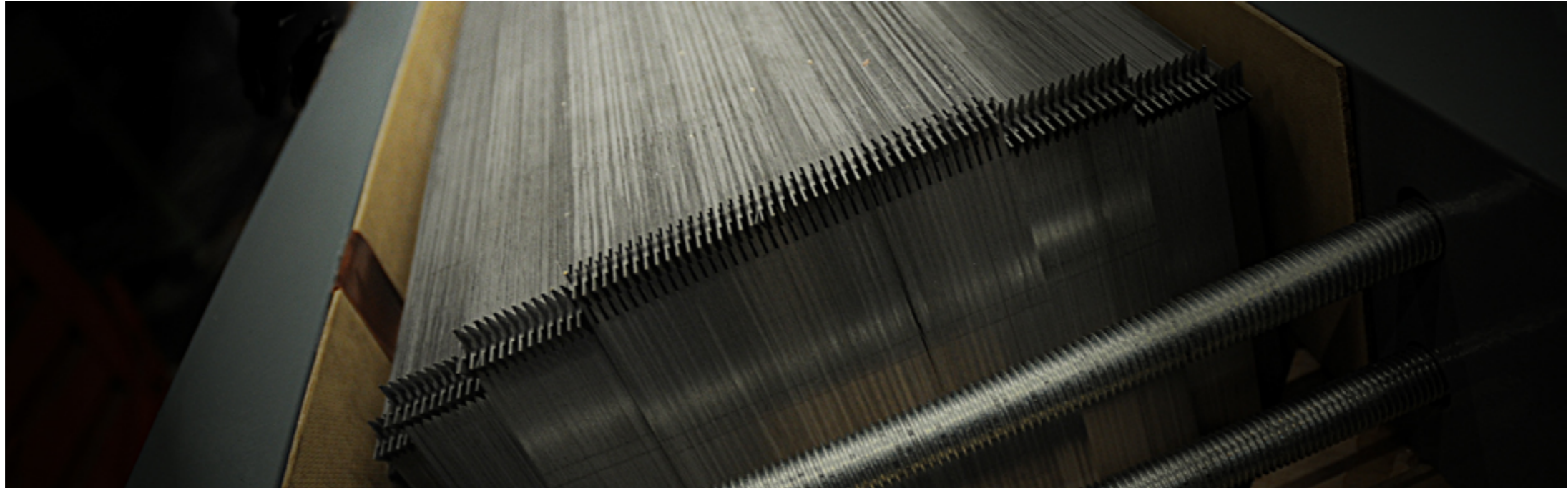

The core is constructed with columns of sheet cold-rolled, grain oriented magnetic steel and insulated from each other with carlite. The core, completely mounted, is blocked so as to reduce vibrations to a minimum, guaranteeing a low noise level.

Conventional grain oriented steel (CGO steel) is used for transformers with normal no-load losses, while transformers with reduced no-load losses are built using higher quality HiB steel. These steel sheets are usually 0.27 mm and 0.30 mm thick. The core sheets are cut at an angle of 45° in order to maximize the magnetic flux linkage. Then the sheets are stacked in layers of either single or multiple overlaps. The multiple overlap or step-lap method offers additional benefits in terms of lowering no-load losses and noise levels.

Once the sheets are stacked, the core is compressed and fixed. The majority of ZENNARO® oil filled transformers are produced with oval-shaped core section obtained combining a round shaped section (that offers an excellent short circuit withstand capability of the windings) with a square mid section combined.

The Windings

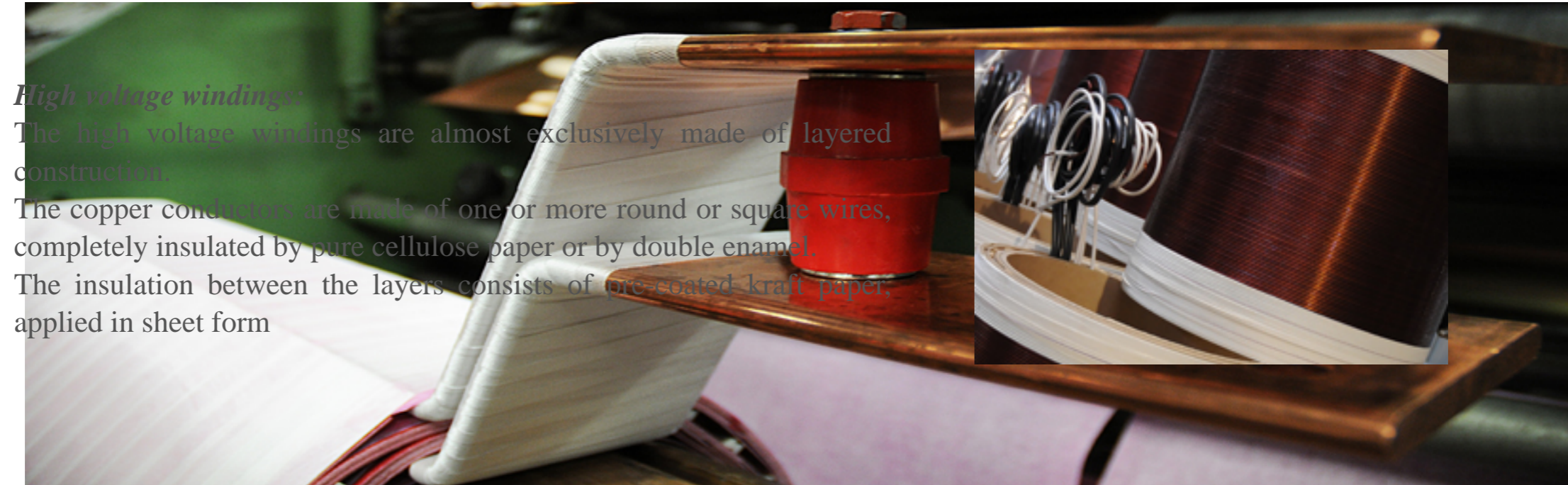

High voltage windings:

The high voltage windings are almost exclusively made of layered construction.

The copper conductors are made of one or more round or square wires, completely insulated by pure cellulose paper or by double enamel.

The insulation between the layers consists of pre-coated kraft paper, applied in sheet form

The high grade of the windings underline the quality of ZENNARO® transformers.

On load during continuous duty they may be stressed by electromechanical effects, caused by short circuit and overloaded by particular needs of network.

Low voltage windings:

The low voltage windings are almost made of copper sheet conductor (foil); this reduces the axial stresses produced by short circuit to a minimum.

The sheets and connectors welded onto them are made of electrolytically pure copper with a rigorously guaranteed conduction.

The maximum voltage between each turn is only few volts.

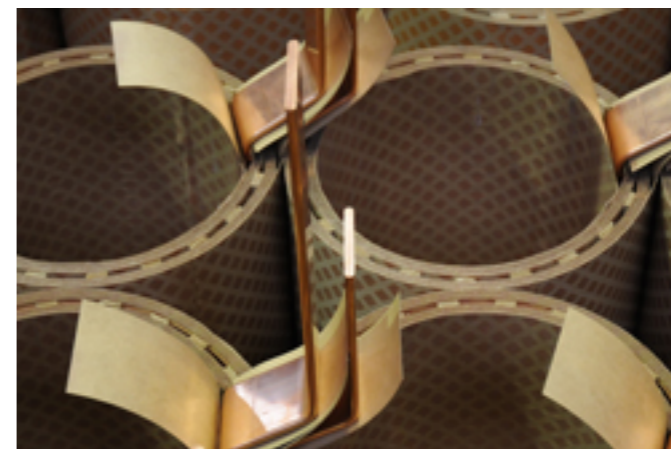

The Tank

The majority of distribution transformer tanks are constructed with cooling fins. The demand for panel radiator type is limited. Radiators are requested and recommended for transformers of nominal power above 5 MVA. The tank has to withstand all the mechanical strains during transportation and on load during continuous duty of the transformer. Furthermore in hermetically sealed transformers, the cooling fins are designed in order to withstand also the internal pressure occurred during the treatments and oil filling under vacuum.

The breathing type transformer has the conservator fitted on the cover. This cylindrical conservator is an expansion for the oil-tank when the windings heat up and often is fitted with oil-level gauge, silica-gel breather in order to ensure that only dry air atmospheric pressure can come in contact with the insulating oil.

The tank is shot-blasted to remove any scale, oil or other surface impurities, leaving a clean prepared surface for maximum adhesion of the paint coating. Air-drying paint is then applied by spraying. The tanks are varnished in a powder automatic equipment by means of a first washing treatment with high-efficiency polyvalent phosphor-degreasing liquid, a subsequent coat 70 micron thick of epoxy resin primer and a final coat of thermosetting powder 100 micron in thickness in color of RAL scale, polymerized at 180 °C. The tanks get a good appearance and an outside agents strength. The tanks may be hot-dip galvanized upon request. This is often requested for transformers constantly exposed to the elements, for pole-mounted or platform-mounted transformers.

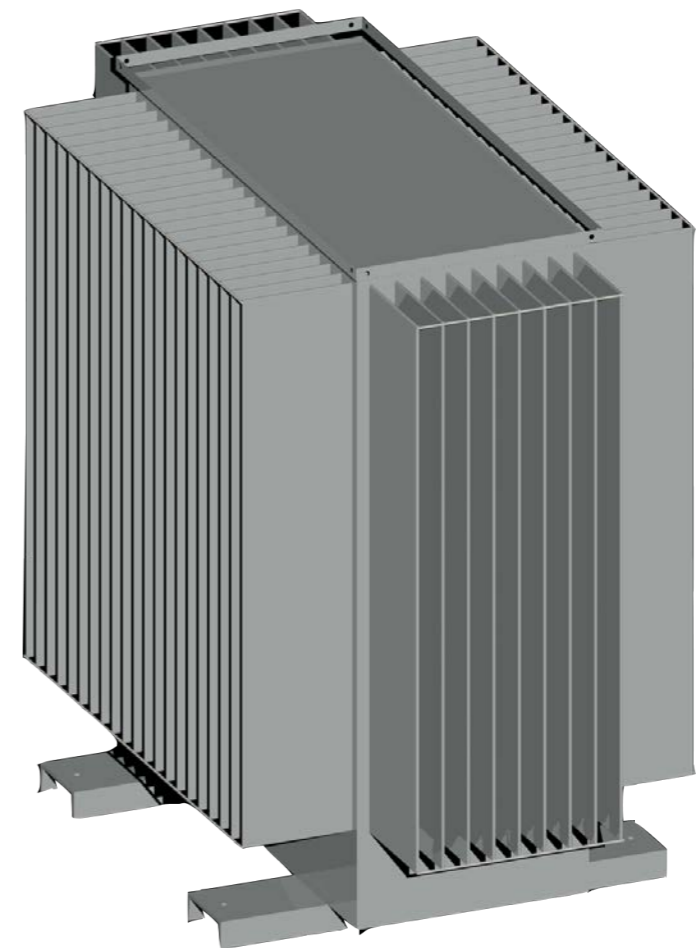

The Active Part



The E-shaped cores and the windings from their various departments are transported to the assembly area.

The windings are pushed over the core legs and wedged up to fill their spaces between the core and winding as much as possible. The bushing are mounted on the cover, which is then fixed into the assembled active part. The transformers are often fitted with an off-circuit tap changer. A second tap changer is incorporated in transformers with dual high voltages in order to change the high voltage.

Once the active part has been dried in the forced-air oven, it is given a final comprehensive quality inspection and placed into the tank.

The transformers are placed in a vacuum chamber and filled with pre-treated oil under deep vacuum.

The transformers are filled with a high quality mineral oil, which fully complies with the requirements of *IEC 60296* standards.

Standard Fittings

1. Rating plate
2. H.V. bushings
3. L.V. bushings
4. H.V. tapping switch
5. H.V. double primary voltage switch
6. Buchholz relay
7. Oil filling and plug
8. Thermometer pocket
9. Lifting lugs
10. Earthing terminal
11. Oil drain valve
12. Rollers or skids



Silica gel breather

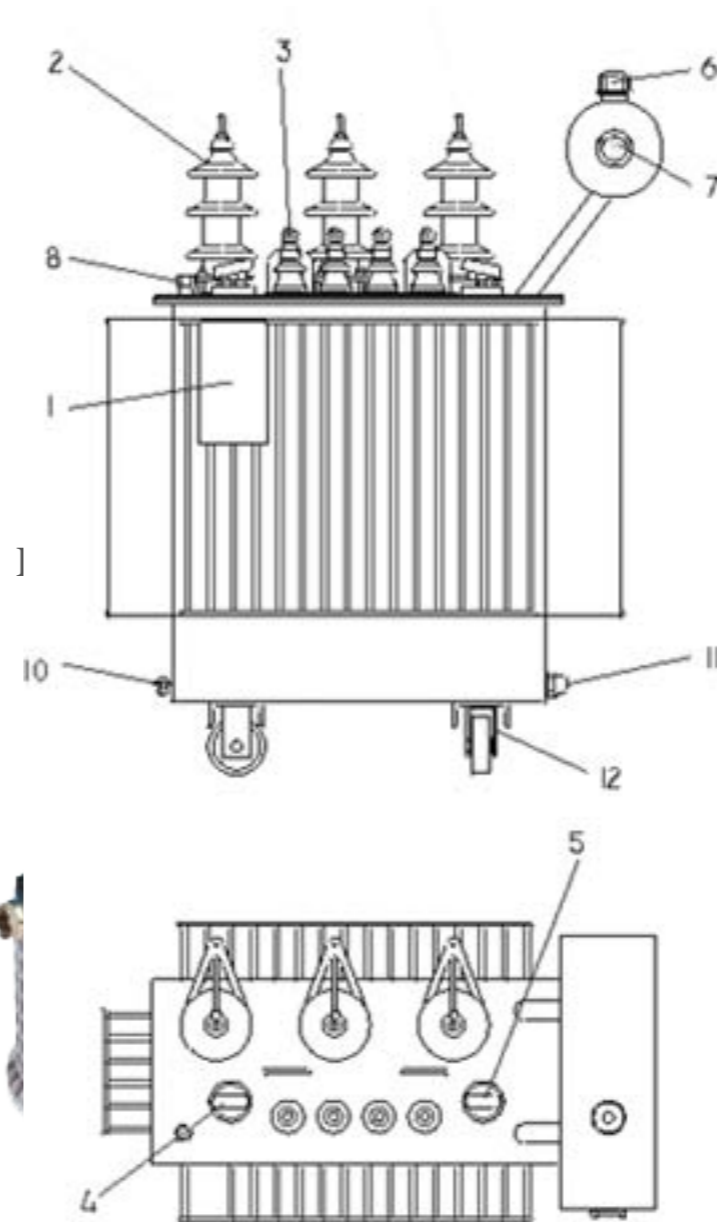

Relief vent valve

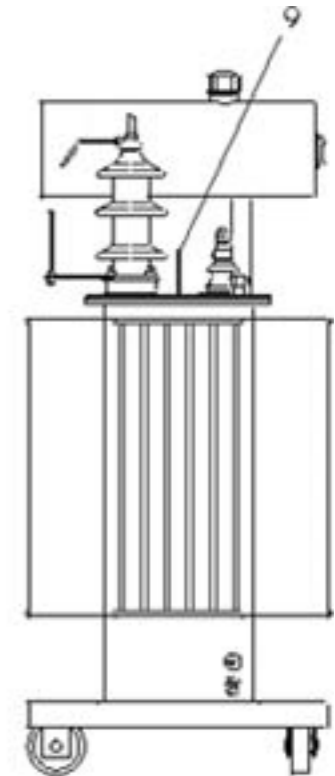

Oil level indicator

Cast Resin Transformer



The Core

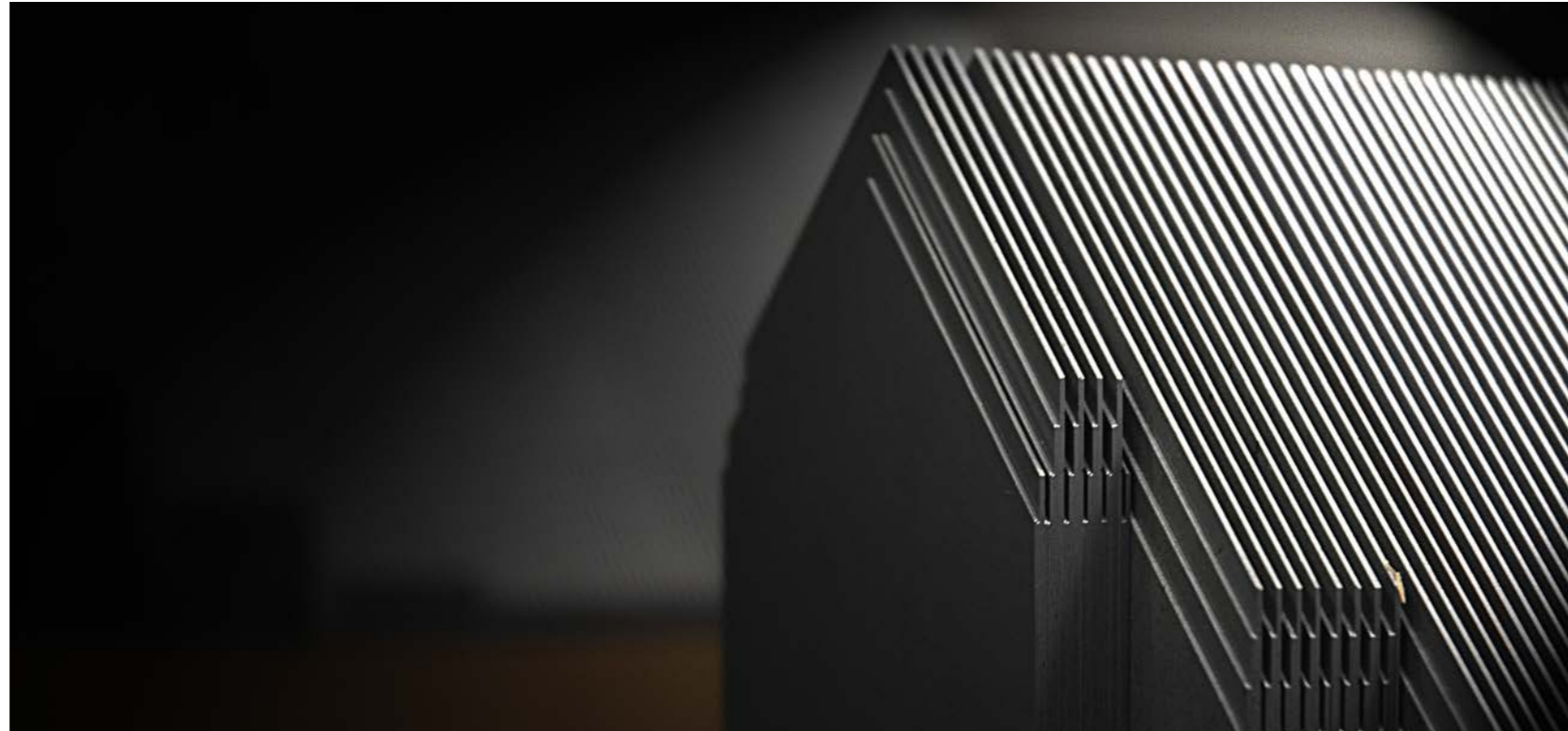

The core is constructed with columns of sheet cold-rolled, grain oriented magnetic steel and insulated from each other with carlite. The core, completely mounted, is blocked so as to reduce vibrations to a minimum, guaranteeing a low noise level.

Conventional grain oriented steel (CGO steel) is used for transformers with normal no-load losses, while transformers with reduced no-load losses are built using higher quality HiB steel. These steel sheets are usually 0.27 mm and 0.30 mm thick. The core sheets are cut at an angle of 45° in order to maximize the magnetic flux linkage. Then the sheets are stacked in layers of either single or multiple overlaps. The multiple overlap or step-lap method offers additional benefits in terms of lowering no-load losses and noise levels.

The Windings

High Voltage Windings

The high voltage windings are made out of copper/aluminum and are so designed to avoid that thermal expansion causes slips between conductors and resin. They are carried out so as to effectively resist stresses caused by short circuit. The method of manufacture guarantees a perfect distribution of the electric field, no partial discharges as well as an excellent resistance to impulse stress. Guarantees have also been planned to resist the external dynamic effects of short-circuit. The dielectric materials employed (resin, conductors and insulators) are class F or H. The transformer has a working temperature rise limit of 100°C (Class F) or 125° (class H).

Low Voltage Windings

The low voltage windings are obtained from copper/aluminum with the same height of the primary limb to reduce to a minimum the axial strain due to short circuit currents. A class F or H insulating block insulates the coils. Before mounting, the LV windings are immersed in alkyd resin and then polymerized at 150°C. This process guarantees excellent resistance to external agents (humidity and pollution of the atmosphere). The winding is designed and made out so that the maximum working temperature rise at full load is equal to class F ($\Delta T=100^{\circ}\text{C}$) or class H ($\Delta T=125^{\circ}$). The concentric shape of the two windings (HV and LV) is maintained by special spacers supports, which allows the supply flux to be uniformly distributed and avoids the onset of abnormal vibrations.

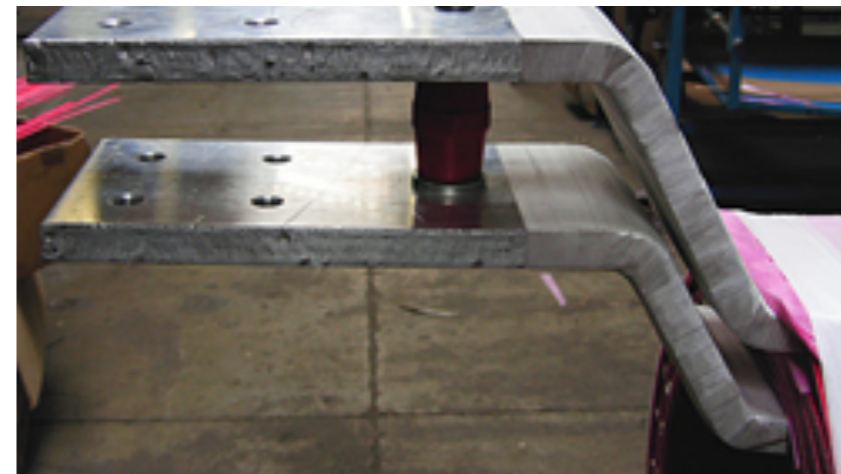
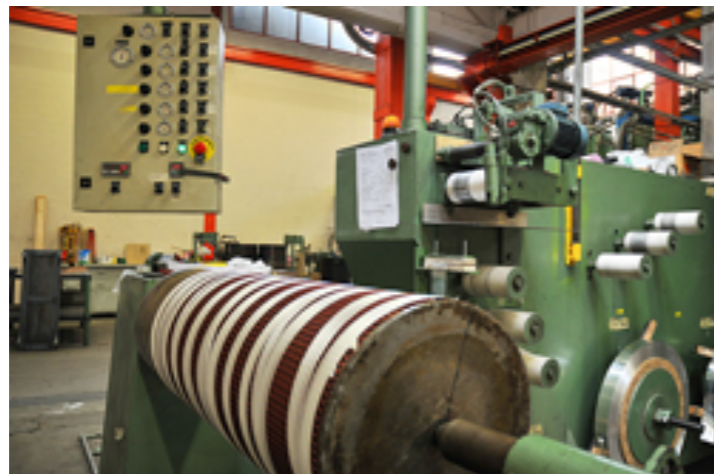

The Casting Plant

The high technology of our casting plant, the care taken in making the moulds, combined with the high quality raw materials

used, enable ZENNARO® to produce the highest quality cast resin coils. The daily tests carried out to verify the level of partial discharges in the coils and measure the glass transition TG coefficient, underline the high quality manufacture of ZENNARO® cast resin transformers. The epoxy resin used by ZENNARO® is class F and H thermal stability and the product is manufactured in conformity with the temperature limits given by the IEC 60076-11 standards. The standard of the plant, the control system software, and particularly the epoxy resin allow ZENNARO® to obtain a high level product under constant computerized monitoring. The resin used in the casting system is an epoxy resin charged with very fine quartz powder, giving the transformer the necessary characteristics to pass successfully every test. The computerized monitoring ensures the accurate control of all phases of the process, from the preparation of the resin to the temperature control in the polymerization stages and to the corresponding TG measuring.

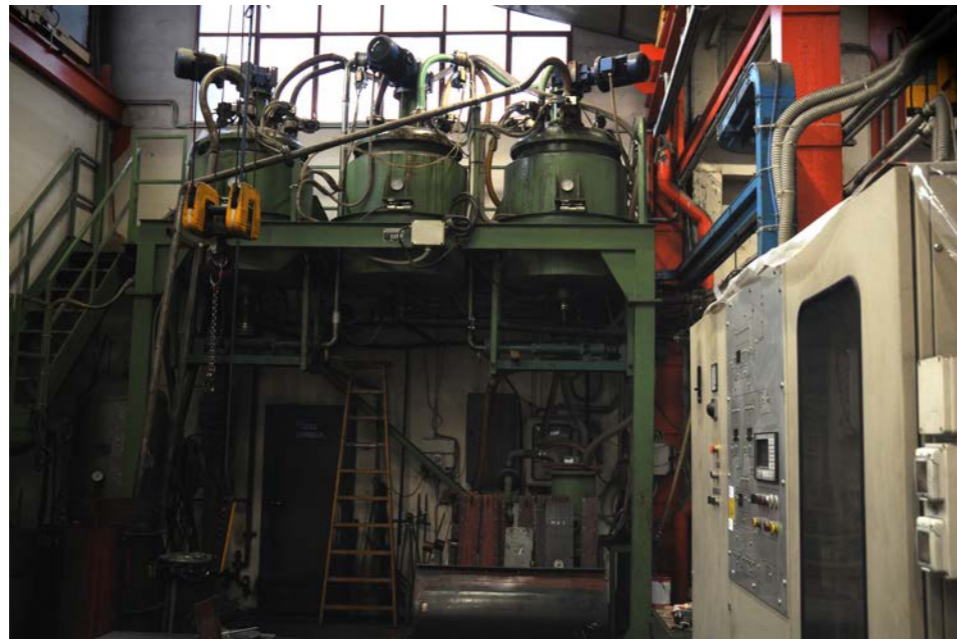

Standard Fittings



1. Rating plate
2. H.V. terminals
3. L.V. terminals
4. Lifting lugs
5. Box for auxiliary circuits
6. H.V. tapping switch
- 7.
- 8.
- 9.

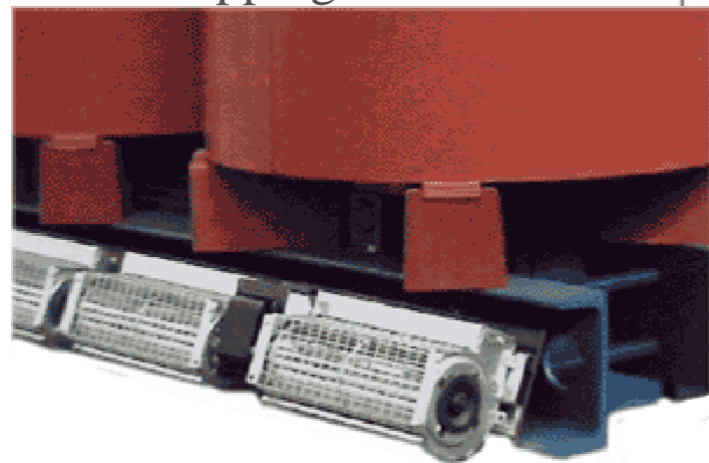

Forced air cooling

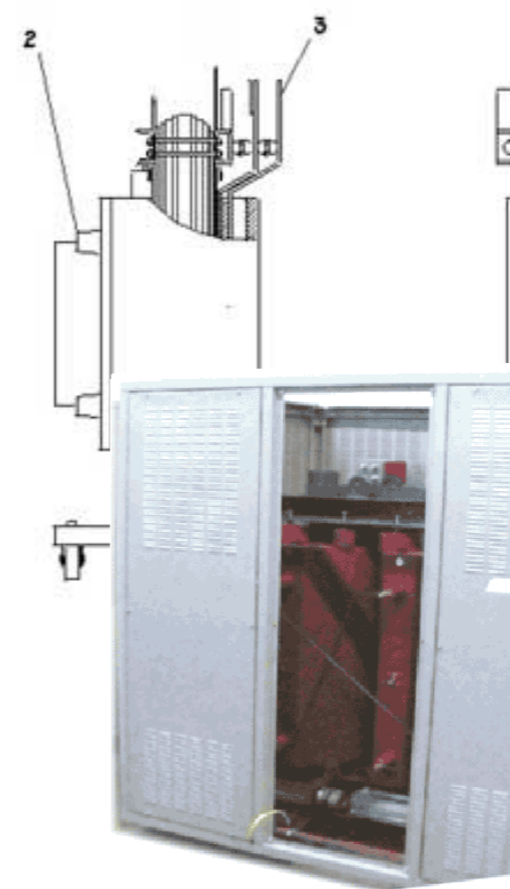
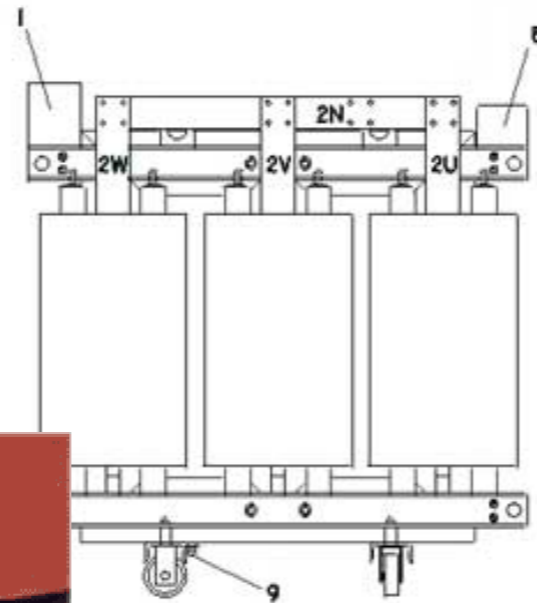

Protection Box

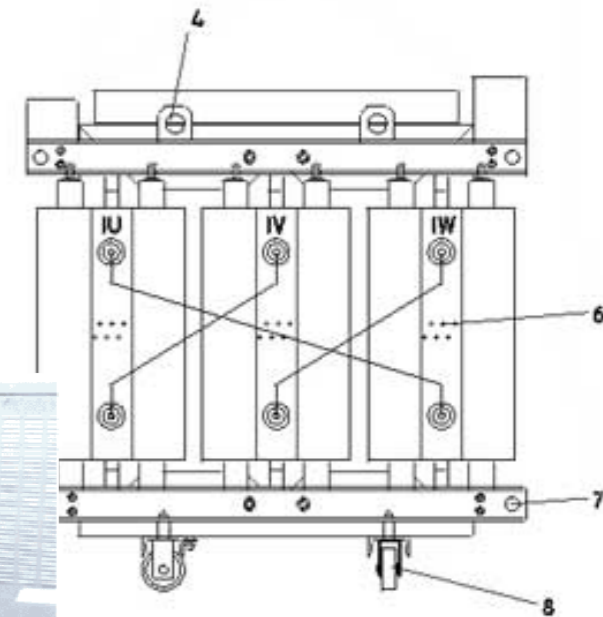

Outdoor pole mounted

Absolute innovation in distribution MV/LV transformers market, the ZENNARO® three phases outdoor pole mounted distribution transformer cast resin type without any protection enclosure were successfully installed in particular weather conditions.

The peculiarity of this type of transformer is the resin class type (E2;C2;F0) made for *external use* which allows to:

- Remove any environmental risk for fire or possible leakage in traditional oil type.
- Reduce the dimensional space in the distribution network system with no need for setting tank for oil scattered.
- Remove all costs related to the maintenance because the transformer structure can be easily checked and there is no need to carry out the gas chromatographic test and the dielectric strength of the insulation oil.
- Discourage any attempt of theft of copper because there is no possibility to remove the windings casted by resin from the block.

The transformers are manufactured according to the latest technical design methods in compliance with the best performance materials in construction phase related to the environmental ambient.



Earthing Transformer



Earthing / Auxiliary transformer manufactured according to the latest IEC 60076-6 create physically a star neutral point in medium voltage due a zig-zag primary windings connection in order to be connected with an arc suppression coil (i.e. Petersen Coil).

Hermetically sealed, with conservator or cast resin type could be manufactured on request according to the value of rated neutral short time and continuous current. A secondary auxiliary winding in low voltage could be added according to the rating power needed for feeding auxiliary system.

Petersen Reactance Coil

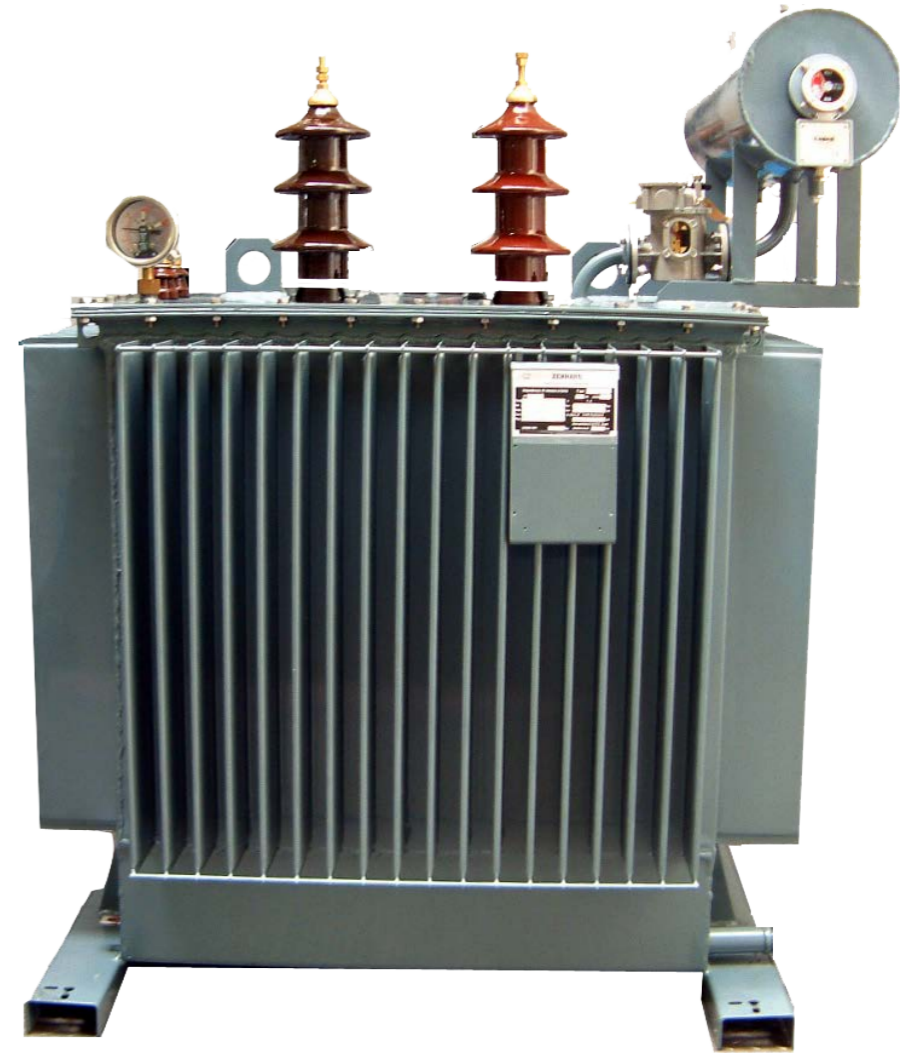

Reactance fixed coil manufactured according to the latest IEC 60076-6 are usually intended for use in M.V. substation.

The value of earthing reactance could be adjust with a manual off load tap changer (range and step on request) depending on the value of rated short time current.

Reactance coil (i.e. Petersen fixed coil) is preferably intended for M.V. network but installation on networks with lower voltage level could be effected, in this case current is consequently reduced.

Testing Room

Routine Tests

Are carried out on all transformers prior to delivery.

- Measurement of winding resistance
- Measurement of voltage ratio and check of phase displacement
- Measurement of short-circuit impedance and load losses
- Measurement of no-load losses and current
- Separate-source voltage withstand test
- Induced over voltage withstand test
- Partial discharges measurement for cast resin transformer
- Tests on on-load tap changer (Power transformer)

Type Tests

May be carried out on request.

- Lightning Impulse test
- Temperature rise test
- Measurement of dielectric strength of the insulation oil
- Measurement of the harmonics of the no-load current

Special Tests

- Determination of capacitances windings-to-earth, and between windings
- Measurement of zero-sequence impedance(s) on three-phase transformers
- Measurement of sound levels
- Short circuit withstand test at an independent laboratory (*CESI/KEMA/LAB.SVEPPI*)
- Check of mineral oil free from PCB

ZENNARO®		TRANSFORMER TEST CERTIFICATE							
ELECTRICAL CONSTRUCTIONS		PURCHASER							
30175 MARGHERA - VENICE (ITALY) P.O. Box 203 ☎ 39.041932744 Fax 39.041927758 e-mail info@zennarotrafo.com		PRODUCTION ORDER							
		ORDER N°							
TRANSFORMER TYPE		MAKER'S SERIAL N°			RATING KVA				
VOLTAGE		H.V. CURRENT			L.V. CURRENT				
VECTOR DIAGRAM		VECTOR SYMBOLS			PHASES				
					IMPEDANCE %				
					FREQUENCY				
MEASUREMENT OF VOLTAGE RATIO - potentiometer method									
POS.	RATIO TURNS			TESTED RATIO TURNS					
	VOLTS AT NO LOAD	VOLTAGE RATIO		U-V / u-n		V-W / v-n		W-U / w-n	
1								W-U / w-n	
2									
3									
4									
5									
6									
MEASUREMENT OF NO-LOAD LOSSES AND CURRENT									
VOLTS-K 1	AMPERES-K 1				WATTS-K 1			INPUT WINDING FREQUENCY	
V	I ₁₁	I ₁₂	I ₁₃	I _{1average}	W ₁₁	W ₁₂	W ₁₃		Σ W ₁
								TESTED	GUARANTEED
								No-load losses watts	
								Current %	
MEASUREMENT OF LOAD LOSSES AND IMPEDANCE VOLTAGE									
VOLTS-K 1	AMPERES-K 1				WATTS-K 1			INPUT WINDING FREQUENCY	TEMP. °C
V	I ₂₁	I ₂₂	I ₂₃	I _{2average}	W ₂₁	W ₂₂	W ₂₃		
								TESTED	GUARANTEED
								Load losses watts	
								Impedance %	
DIELECTRIC TESTS				MEASUREMENT OF WINDING RESISTANCE (TEMP. 32° C)					
SEPARATE-SOURCE VOLTAGE WITHSTAND TEST		INDUCED OVERVOLTAGE WITHSTAND TEST		H.V. WINDING CONNECTION	TERMINALS	VOLT - K 1	AMPERE - K 1	AVERAGE WINDING RESISTANCE Ω	
BETWEEN H.V. AND L.V. TO EARTH		INPUT WINDING		T	U - V				
DURATION		WITH			V - W				
BETWEEN L.V. AND H.V. TO EARTH		FREQUENCY		L.V. WINDING CONNECTION	TERMINALS	VOLT - K	AMPERE - K	AVERAGE WINDING RESISTANCE Ω	
DURATION		DURATION		S	u - n				
					v - n				
				w - n					
THE TRANSFORMER IS CONNECTED TO VOLTS				DATE TESTED BY				ZENNARO® ELECTRICAL CONSTRUCTIONS	

Quality System

Since the beginning, ZENNARO® has always concentrated on constant quality upgrading in all sectors: production, technology and organization.

Our quality management system has been assessed and registered as meeting the requirements of ISO 9001 as per enclosed certificate n°IT97/0180 issued on 27/10/1997.

SGS , the certification company , inspects and tests our quality system twice a year.

Quality control manual and procedures manual consisting of more than 1000 pages are available in italian language.

Certificate N. IT97/0180

SGS

The quality management system of

ZENNARO COSTRUZIONI ELETTRICHE S.r.l.

Registered and Head Office :
Via Volta, 34 - 30175 MARGHERA (VE) - Italy

Operation Unit:
Via dell'Elettricità, 11/A - 30175 MARGHERA (VE) - Italy
has been assessed and certified as meeting the requirements of



ISO 9001 / UNI EN ISO 9001:2008

For the following activities

Design and manufacturing of electrical transformers.

EA Sector: 19

This certificate is valid from 28/04/2013 until 28/04/2016 and remains valid subject to satisfactory surveillance audits.
Re certification audit due before 28/04/2016.
Issue.5. Certified since 27/10/1997.

Further clarifications regarding the scope of this certificate and the applicability of ISO 9001:2008 requirements may be obtained by consulting the organization.



Authorized by
Paola Santarelli

A handwritten signature in black ink, appearing to read 'Paola Santarelli'.

SGS ITALIA S.p.A. - Systems & Services Certification
Via G. Gozzi, 1/A 20129 MILANO - Italy
t + 39 02 73 93 1 f +39 02 70 10 94 89 www.sgs.com

Page 1 of 1



This document is issued by the Company subject to its General Conditions of Certification Services accessible at www.sgs.com/terms_and_conditions.htm. Attention is drawn to the limitations of liability, indemnification and jurisdictional issues established therein. The authenticity of this document may be verified at <http://www.sgs.com/en/Our-Company/Certified-Clients-Directories/Certified-Clients-Directories.aspx>. Any unauthorized alteration, forgery or falsification of the content or appearance of this document is unlawful and offenders may be prosecuted to the fullest extent of the law.

References



EUROPE

ITALY: ENEL DISTRIBUZIONE S.P.A.

A2A RETI ELETTRICHE S.P.A.

ASM TERNI S.P.A.

SET DISTRIBUZIONE S.P.A.

AMAIE S.P.A. SANREMO

SPAIN: ASEA BROWN BOVERI S.A.

ROMANIA: ELECTRICA DISTR. MUNTENIA NORD S.A.

ELECTRICA DISTR. TRANSILVANIA NORD S.A.

ENEL DISTRIBUTIE DOBROGEA S.A.

ENEL DISTRIBUTIE BANAT S.A.

ENEL DISTRIBUTIE MUNTENIA S.A.

E.ON MOLDOVA DISTRIBUTIE S.A.

SWEDEN: ELTEL NETWORKS TE AB

CZECH REP: EGE SPOL. SR.O.

ENGLAND: COMICEL LTD

BELGIUM: COMELEC S.A.

CROATIA: RAMIC TRADE

SOUTH AMERICA

VENEZUELA: FABR. METALICAS NACIONALES C.A.

(FAMENACA)

SURINAME: ENERGIJEBEDRIJEN SURINAME (EDS)

AFRICA

MAURITIUS: REY&LENFERNA LTD.

CENTRAL ELECTRICITY BOARD (CEB)

ETHIOPIA: ETHIOPIAN ELECTRIC POWER CO. (EPPCO)

ERITREA: ERITREA ELECTRICITY AUTHORITY (EEA)

NIGERIA: NATIONAL ELECTRIC POWER AUTHORITY (NEPA)

GHANA: ELECTRICITY COMPANY OF GHANA LTD

VOLTA RIVER AUTHORITY

SUDAN: SUDANESE ELECTRICITY DISTR. CO. (SEDC)

MIDDLE EAST

IRAQ: AL-NAJAF GOVERNORATE

ERBIL GOVERNORATE

IRAQ MINISTRY OF ELECTRICITY (MOE)

MOSUL GOVERNORATE

JORDAN: IRBID DISTRICT ELECTRICITY CO. LTD

BAHRAIN: CAPITAL ELECTRICAL EQUIPMENTS

PALESTINE: AL OMAR COMPANY LTD.

GAZA ELECTRICITY DISTR. CO. LTD. (GEDCO)

KSA: ARABIAN TRANSFORMERS CO.

PAKISTAN: TMA INTL

Contacts



QUICK CONTACT:

**Via A. Volta 34
30175 - Marghera Venice - Italy**

**Tel: +39 041-932744
Fax: +39 041-927758
e-mail: info@zennarotrafo.com**